



Instruction Manual

Read this instruction manual to properly install and operate this system.



Content

Product and Accessories	1
Installation Schematic Diagram	2
Installation Instructions	3
Cartridge Replacement	6
Trouble Shooting	8
Precautions for Use	9
Technical Specifications and Water Treatment Process Flow Diagram	10
Warranty	11

Product and Accessories

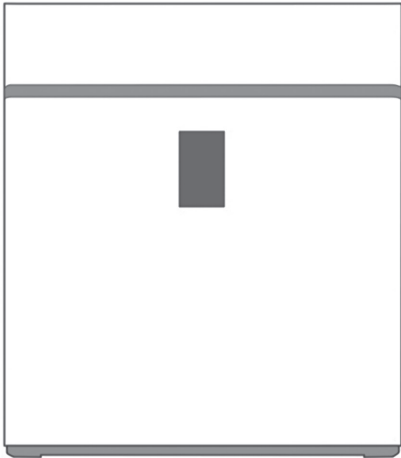

Main Body

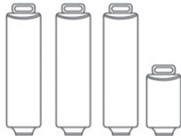

Four Filter Cartridges

Includes spun PP filter(PP), block carbon filter (CTO), reverse osmosis membrane (RO) and post activated carbon filter (T-33).

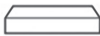

One Accessory Box

Includes faucet, 3-way ball valve, three pieces of tubing, instruction book, adapter and drain clamp. Reference Images for Accessories.

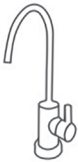

Faucet



Faucet connector

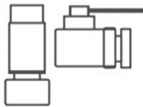

3-Way ball valve



3 Colored tubing (red, blue and green)



Instruction book



Transformer



Drain clamp

Note: Pictures are for reference only and subject to availability.

Installation Schematic Diagram

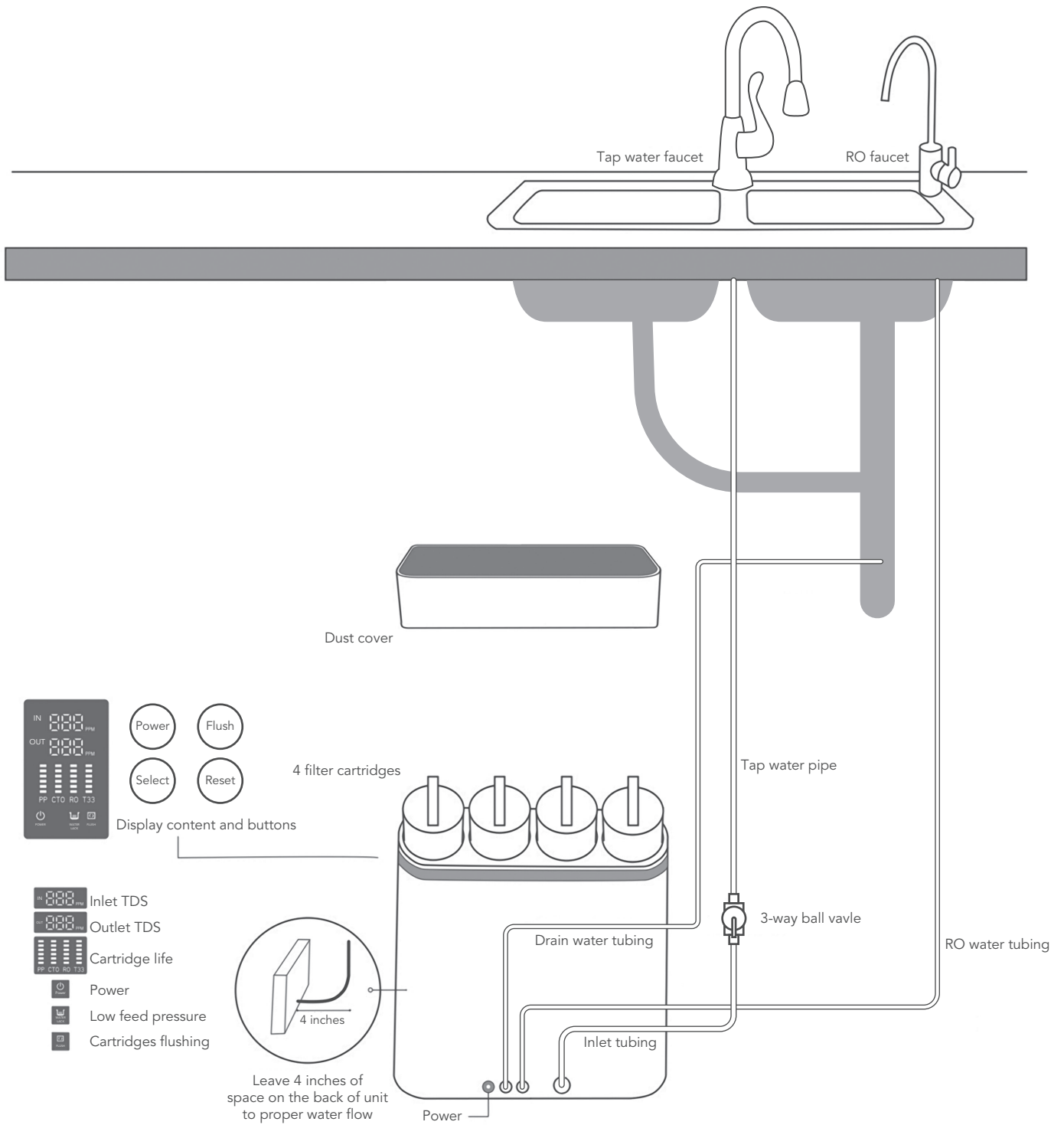

Installation

Tapping Into The Cold Water Line

(Using the water supply adapter 3-way ball valve)

For flex metal or plastic line.

NOTE: QC-RO system must be connected to the COLD water supply only.

- 1) Turn off the **cold** water supply to the sink faucet by locating the round or oblong handle and turning clockwise until the water supply is off.

NOTE: If the cold water shut off valve fails to turn off the water, the house supply can be turned off at the main water supply.

- 2) The water supply adapter may be installed at the faucet connection.
- 3) Disconnect the 3/8" flex line from the base of cold water basin supply angle stop valve.
- 4) Re-connect the 3/8" 3-way ball valve to the basin supply angle stop valve.
- 5) Re-connect flex line to the 3-way ball valve .
- 6) Push green tubing in to Quick Connect fitting up to tube stop. Pull on the tubing to check it is secure. Test the system before use.

NOTE: All local plumbing codes must be followed to ensure proper installation and use of your system.

CAUTION: A pressure regulator is recommended for feedwater pressure above 60psi.

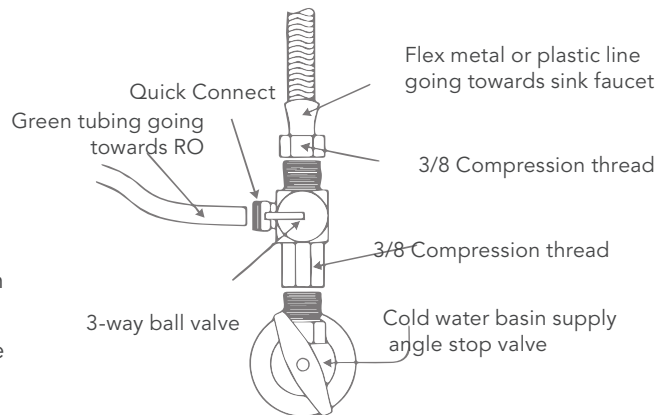

Tools Required:

- 1) **Hand drill for faucet hole. Use the appropriate bit for the surface you are drilling. (1/2" for non air gap faucets and - 7/8" drill bit for air gap ones).**

A) Titanium bit for metal sinks.

B) Glass and tile bit or Relton cutter for porcelain sinks.

C) Diamond core bit for granite.

- 2) Phillips head screwdriver.

- 3) Adjustable crescent wrench.

- 4) Basin wrench.

- 5) 1/4" drill bit for drain clamp.

Drilling the hole for the faucet

NOTE: SAFETY GLASSES SHOULD BE WORN TO PROTECT YOUR EYES WHILE DRILLING THE FAUCET WHOLE.

- 1) For best results, a 1/2" drill bit for a non air gap faucet or 7/8" drill bit for an air gap faucet should be used to drill a hole into your sink for the auxiliary faucet.
- 2) Carefully select the faucet location making sure it will have a neat water fall pattern and that the faucet stud will be accessible from below once the whole is completed.

- 3) **For Porcelain Sink:** Before starting the drill motor, apply firm downward pressure on the bit until a crunching occurs. This will help keep the drill from moving when starting the hole. Use a special porcelain hole cutter.

- 4) **For Stainless Steel Sink:** Before using the selected bit, an indent should be made with a center punch to keep the drill bit from moving. A small pilot hole will also aid the drill process.

- 5) For best results, keep steady firm pressure while drilling the hole. Too little pressure during the start will cause excess wear on the bit and progress will be slow.

- 6) Once the hole is complete, clean the area of metal chips and roughness around the hole. Metal chips will stain porcelain.

Warning: It is highly recommended for granite slate countertops, to use the assistance of a licensed professional to drill the hole for the faucet. Serious damage can occur to the counter if done by an inexperienced person.

Mounting The Faucet

Standard Faucet

- 1) Drill a 1/2" hole in the sink or the counter top, or use an existing hole.
- 2) Slide chrome cover plate and rubber gasket on to stem of faucet and place faucet onto sink, with the stem going through the hole.
- 3) Place metal slotted washer over threaded stem of faucet.
- 4) Tighten nut from under the counter surface to lock the faucet into place.
- 5) Thread the faucet connector onto threaded stem of faucet. Do not use Teflon tape.
- 6) Connect blue 3/8" tubing to faucet connector.

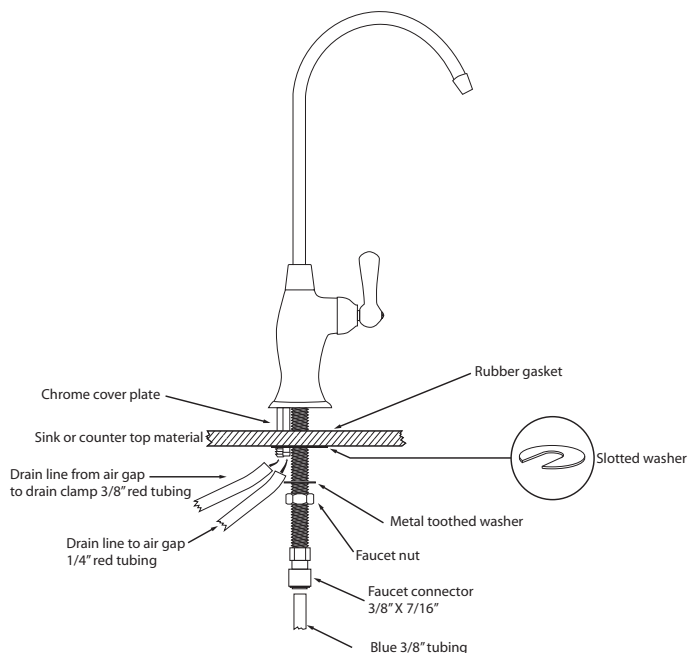
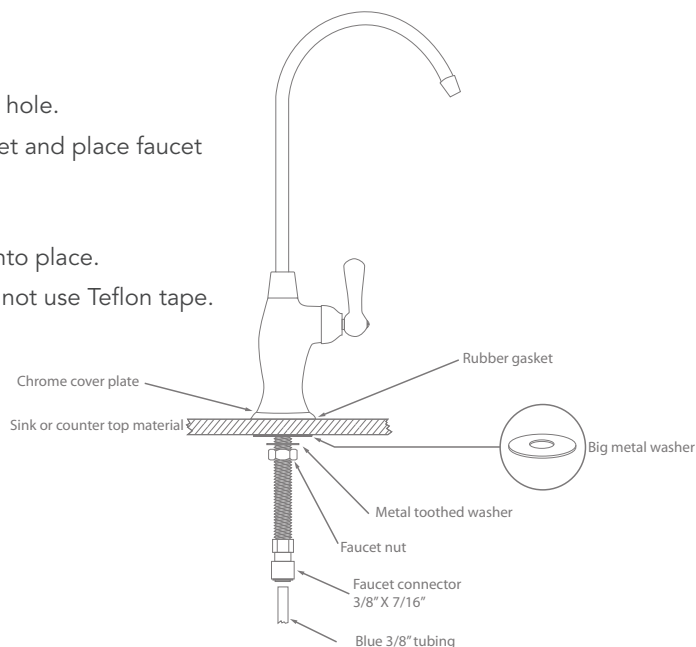

Air Gap Faucet (Optional)

- 1) Drill a 7/8" hole in the sink or the counter top, or use an existing hole.
- 2) Slide chrome cover plate and rubber gasket on to stem of faucet and place faucet onto sink, with the stem going through the hole.
- 3) Place metal slotted washer over threaded stem of faucet.
- 4) Place plastic spacer over threaded stem of faucet locking in place, slotted washer onto countertop.
- 5) Tighten nut from under the counter surface to lock the faucet into place.
- 6) Attach red 1/4" drain water discharge line to DRAIN INPUT barb. And red 3/8" drain line to DRAIN OUTPUT barb as shown.
- 7) Thread the faucet connector onto threaded stem of faucet. Do not use Teflon tape.
- 8) Connect blue 3/8" tubing to faucet connector.

Compression Connections

A compression fitting may be found with the faucet. To make the connections, slide a compression nut onto the tubing. Slip the white plastic sleeve onto the tubing with the beveled end towards the end of the tubing. Insert a brass or plastic insert into the tubing, bottom the tubing into the fitting, slide the nut up and tighten with a wrench. **DO NOT OVER TIGHTEN.** Do not use the brass sleeves on plastic tubing, use only plastic sleeves on plastic tubing.

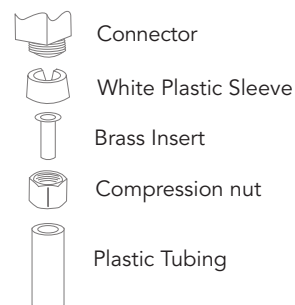

Drain Clamp Installation

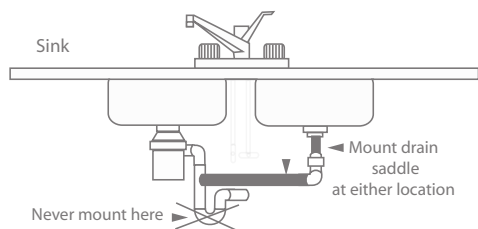

- 1) The drain clamp assembly should be installed above the trap and on the vertical or horizontal tail piece.

- 2) Mark the hole position on the pipe and drill a 1/4" hole through one side of the pipe. Be careful **not** to drill the hole through both sides of the pipe.

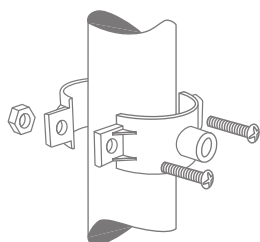
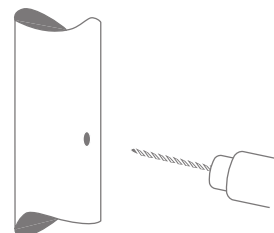

- 3) Affix gasket provided with the drain clamp onto inside of clamp piece matching the holes. The center hole on the gasket must be removed.
- 4) Make sure to align drain saddle to drilled hole. Attach drain clamp to drain pipe and tighten the two screws evenly.
- 5) Connect the 1/4" red tubing to the drain clamp (or 3/8" when air gap faucet is used).

Positioning The System

- 1) The head assembly will stand up in the sink cabinet or can be hung on screws.
- 2) The storage tank may be laid on its side. The bladder tank will function in both a horizontal or vertical position.
- 3) The head assembly and/or storage tank may be placed up to 10 feet from the point of use with some pressure loss.

EZ Fittings-Quick Connect

Your QC-RO system is equipped with EZ fittings. The quick connect fittings feature leak proof installations. EZ Fittings provide efficient quick connection and disconnection resulting in reduction of service time and labor cost.

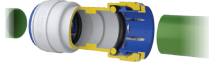
1. Cut tubing square  Cut the tube square. It is essential that the outside diameter be free of score marks and that burrs and sharp edges be removed before inserting into fittings. For soft thin walled plastic tubing, we recommend the use of a tube insert.

2. Insert tube  Fitting grips before it seals. Ensure tube is pushed into the tube stop.

3. Push up to tube stop  Push the tube into the tube stop. The collet (gripper) has stainless steel teeth which hold the tube firmly in position while the o-ring provides a permanent leak proof seal.

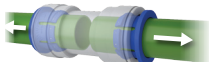
4. Pull to check secure  Pull on the tube to check that it is secure. It is a good practice to test the system prior to leaving site and/or before use.

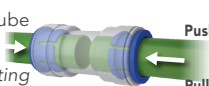
- Push in collet and remove tube  Disconnecting **Push on collet** **Pull on tubing** To disconnect, ensure the system is depressurized before removing the tube. Push in collet squarely against face of fitting. With the collet held in the position, the tube can be removed. The fitting can there be re-used.

First Use Instruction

1. Connect RO system to the transformer. The power indicator will come on, and you will hear three chimes, the machine will flush for 90 seconds while flushing icon blinks.
2. When the system starts filtering water you will see the computer display real-time TDS numbers, the cartridge life span and power indicator will light on. All LED display icons turn off when water tank is full.
3. When the water storage icon flash and the systems chime 10 times, the system has insufficient water or low water pressure. The machine will flush for 5 seconds once it has enough water or water pressure has been restored.
4. If the system stops producing water and has been operating for 6 continues hours, or if it detects a water leak, all icons will start flashing and you will hear the system chime 30 times.

Note: Under normal operation, please run water for 10-15 minutes in order for the cartridges to flush when the system is used for the first time.

Cartridges Replacement

Cartridge reminder

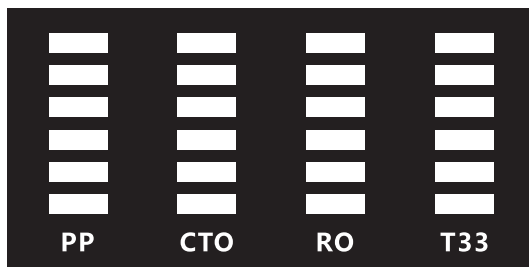

There are 6 LED indicators to show the current lifespan of corresponding cartridge filter. All cubes extinguish when filter's lifespan is over.

Note:

1. Actual lifespan of filters can be influenced by areas, water quality, seasons and daily water consumption, so the period of filters replacement may vary.
2. The indicator life on QCR are set by pump running hours.* (see adjacent table)
3. Please replace regularly.

Recommended Replacement Period for Cartridges

CARTRIDGE	FUNCTION	PUMP RUNING HOURS*	LIFESPAN (FOR REFERENCE ONLY)
Spun PP filter	Removes larger suspended particles in water	50 hour lifespan	3-12 months
Block carbonfilter CTO	Further removes organics, chlorine, odor and turbidity	100 hour lifespan	3-12 months
RO membrane	Removes bacteria, heavy metals, dissolved particles and salinity	200 hour lifespan	12-36 months
Post Carbonfilter T33	Conditions the taste of purified water	100 hour lifespan	3-12 months

Cartridges Reset

Keep pressing Select button for 3 seconds to enter selection mode, then press Select to select the cartridge which needs to be replaced and then press Reset button.

The LED indicators shows full again. The selection mode will exit automatically if there is no operation in 5 seconds.

Filter Cartridges Replacement Steps:

Warning: Do not Turn or Flip-Over the RO

1. Cut off water supply to the RO
2. Open Faucet to drain all water inside the RO
3. Turn RO off
4. Remove the cartridges cap
5. Hold the cartridge handle and rotate 90°counterclockwise, then pull it out

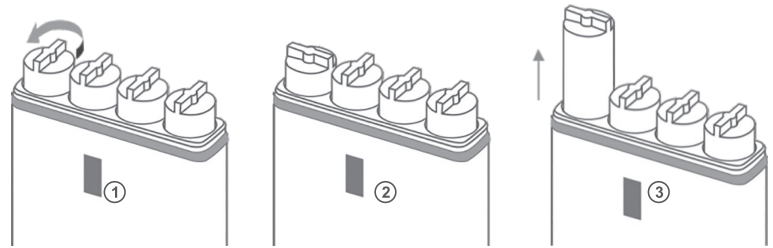

6. Replace it with new cartridge and align the arrow label to "  " and rotate 90°clockwise to "  ".

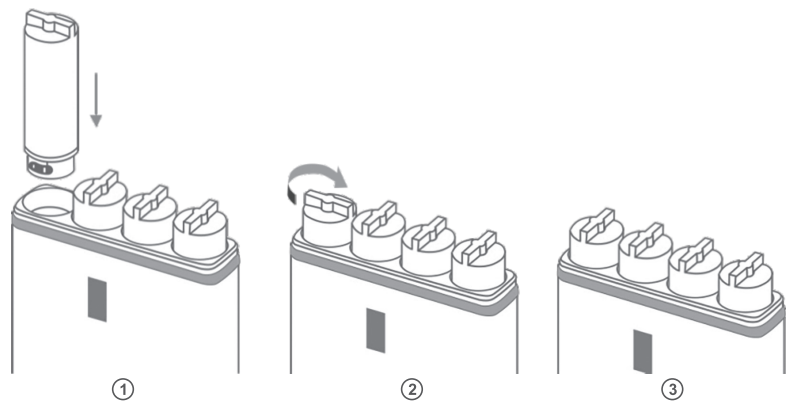

7. Cover the cap after finishing replacement. (The cap is unable to cover when cartridges are not in right place.)

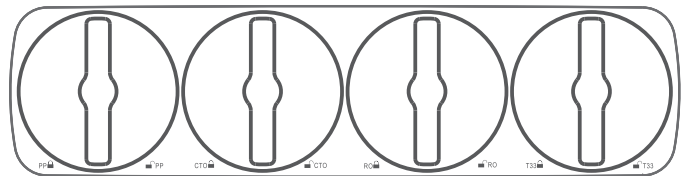

Note: Please reset cartridges after replacement (see page 6).

Trouble Shooting

Problem	Cause	Solution
Water pump is out of service and system does not work	Insufficient feed water pressure	Increase feed water pressure
	No power or power failure	Power-on
	High pressure switch is out of order	Replace high pressure switch
	Pump is blocked and adapter fuse burn-out	Replace adaptor and repair water pump
High TDS value	TDS of feed water is too high or system is placed long term being unused.	Open the faucet to draw off the pure water for a while
	Cartridge lifespan is over	Replace cartridge
Water pump works but system does not work	RO membrane is blocked	Replace RO membrane
	Water pump pressure loss	Repair water pump
	Flush solenoid valve is damaged	Replace flush solenoid valve
Constantly running water in downtime	Inlet water solenoid valve damaged	Replace feed water solenoid valve
Cannot stop working when pressure tank is full or repetitive starting	High pressure switch is damaged	Repair or replace high pressure switch
	Check valve is damaged	Replace Check valve

It is highly recommended to have a water treatment professional do all trouble shooting and repairs, with the exception of filter replacements.

Precautions for Use

Attention

1. Flush and replace cartridges regularly.
2. Do not disassemble parts randomly, it may cause water leak or damage the system.
3. Do not use a power supply that does not have the rated voltage.
4. Please pull the power plug and cut off the feed water valve for long term storage.
5. Do not store or operate in an environment of 32F° or below.
6. Handle with care when discharging, moving and installing.

Reminder

1. If you home experiences the "water hammer phenomenon*", turn off the feed water supply to the unit immediately. Letting this hydraulic shock continue may lead to leakage or damage to the filters and filter housings. Our company does not take responsibility for any damages to the system or for leaks caused by this situation.
2. Please cut off power and source water at once in case troubles occur and ask a professional for assistance.
3. It is normal to hear some vibration sounds when system is producing water.

*Hydraulic shock, commonly known as water hammer or fluid hammer, is a pressure surge or wave caused when a fluid (water), in motion is forced to stop or change direction suddenly; a momentum change. This phenomenon commonly occurs when a valve closes suddenly at an end of a pipeline system, and a pressure wave propagates in the pipe. It sounds like hammering in your water pipes.

